

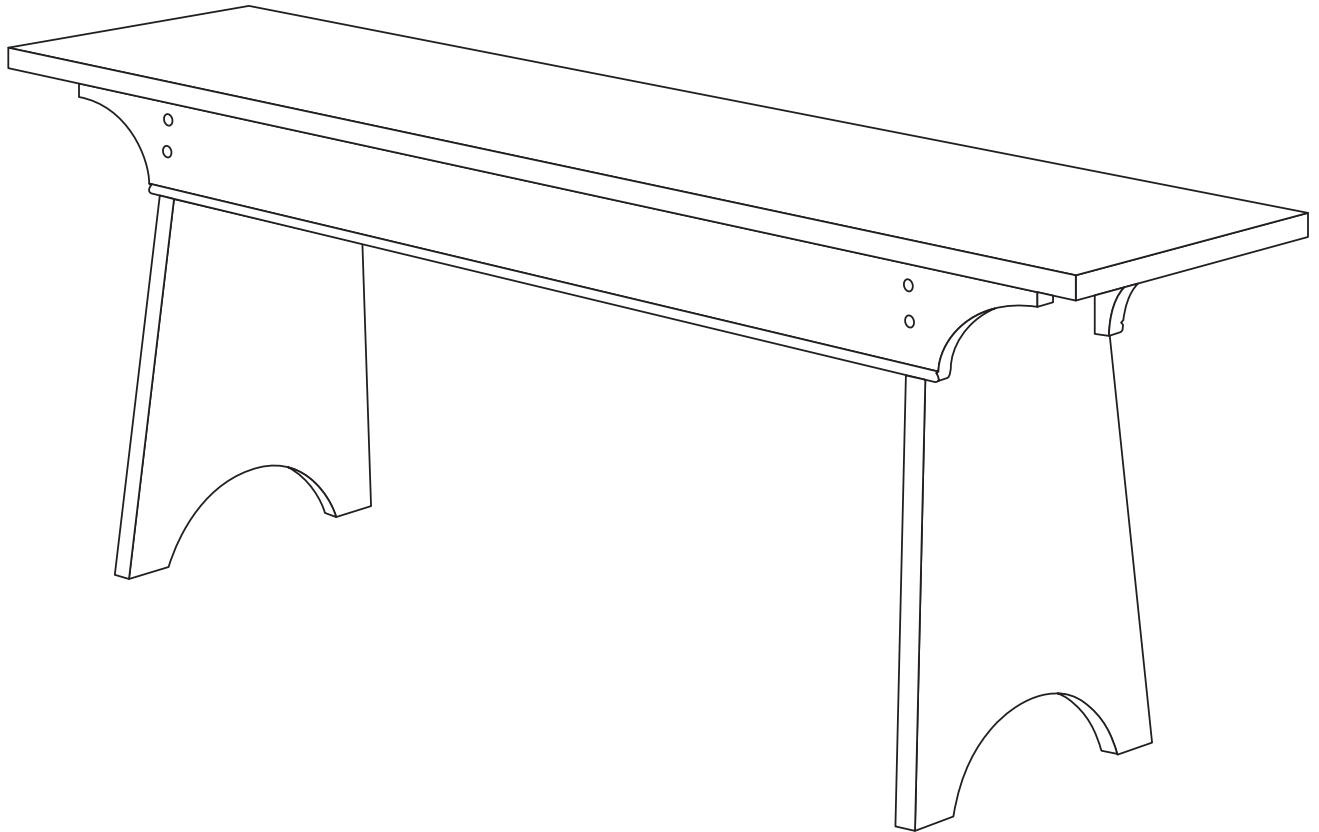

**WOODWORKS: INTERMEDIATE PROJECT 2005-2006**  
**STOWAWAY BENCH**



This country-style bench will cut the clutter by the door and serve as a resting spot to put on your shoes. The lid opens to reveal a handy storage area. At only 11" deep by 44" long, it neatly fits in an entryway or mudroom.

You will add to your intermediate-level skills by learning how to use a table saw sled for making extra-wide crosscuts. You'll learn how to make repeatable cuts by setting up the saw miter gauge with a tall, wide fence and a stop block. You'll also gain experience in making angle and radius cuts in a project that shouldn't take you more than a day to build. After it's assembled, you'll learn more about applying stains and finishes to protect the wood and keep it looking beautiful.

## TOOLS REQUIRED

### Hand Tools

- Chisel
- Hand plane or sanding block
- Bar clamps

### Power Tools

- Table saw with regular and dado blades
- Jigsaw
- Router with a beading bit

### Miscellaneous

- Tape measure
- Pencil
- Safety glasses
- 120-, 150- and 220-grit sandpaper
- Clean, lint-free cloths
- Tape
- Respirator
- Gloves for finishing
- Mineral spirits (for oil-based stains and finishes)

- Water-filled metal container with tight-fitting lid (for oil-based stains and finishes)
- Minwax™ Polycrylic™ Brush or other good quality, synthetic bristle brush (for water-based stains and finishes)
- Minwax™ Wood Finish™ Stain Brush and Minwax™ Polyurethane Brush or other good quality, natural bristle brush (for oil-based stains and finishes)

## SHOPPING LIST

Item	Quantity
1 x 12 x 8' pine	1
1 x 8 x 6' pine	1
1-1/2" x 3" brass butt hinges	2
3/8" dowel rod	1

Recommended wood - Pine (stain grade)

Alternate wood selections - Oak or Douglas Fir

## CUTTING LIST

Overall Dimensions: 17"H x 44"W x 11"D			
Key	Part	Pcs.	Dimensions
A	Lid	1	3/4" x 11" x 44"
B	Legs	2	3/4" x 11" x 16-1/4"
C	Rails	2	3/4" x 3-1/2" x 39-3/4"
D	Bottom	1	3/4" x 7" x 30-3/4"
E	Pegs	8	3/8" x 1-3/4"

## WOOD FINISHING PRODUCTS

### Recommended Finish

- Prep: Minwax® Water-Based Pre-Stain Wood Conditioner
- Stain: Minwax® Water-Based Wood Stain  
Lid - Lemongrass\*  
Rails and legs - Island Water\*
- Finish: Minwax® Polycrylic® Protective Finish Semi-Gloss

### Alternate Finish

- Prep: Minwax® Pre-Stain Wood Conditioner
- Stain: Minwax® Gel Stain Antique Maple  
(or your choice of 8 Minwax® Gel Stain colors)
- Finish: Minwax® Wipe-On Poly Satin or Gloss

\*Or a Minwax® Water-Based Stain of your choice, available in 6 wood tones, a White Wash Pickling Stain, 60 custom colors, and 8 bold Accents™ colors.

## BEFORE YOU BEGIN

Good craftsmanship begins and ends with good work habits, so make the following steps part of your routine workshop practice. If you have any doubts or questions about how to proceed with a project, always discuss them with your instructor.

- Carefully and fully review plans and instructions before putting a tool to the project lumber.
- Work sensibly and safely. Wear safety goggles and the appropriate respirator whenever making sawdust or working with thinners or other solvents.
- At the end of every work session, clean up your shop area and put away all portable tools.

## CUTTING AND ASSEMBLY PROCEDURE

**Woodworker's Tip:** *It's important that the lid (A) be as flat as possible. Since it's common for wide boards to be slightly warped, pick the flattest one for the lid before cutting out any other parts.*

1. Rip and crosscut the lid (A), legs (B) and rails (C) to final dimensions. The legs and lid are too wide to crosscut with a standard table saw miter gauge, but a simple shop-made crosscut sled solves this problem. Or, make the cuts with a power miter saw or a radial arm saw. Cut the bottom (D) to final length, but don't rip it to width. It will be custom fit later on.
2. Cut a dado in each of the two legs (B) as shown in Figs. 1 and 2. Then cut the notches in the upper corners of the legs. This is a three-step process that's illustrated in Fig. 2. Each step requires clamping the leg to a tall, miter gauge fence, as shown in Fig. 4.
3. First, make two vertical cuts in the top of each leg. Most table saws won't be able to cut the full 3-1/2" depth that's required for this cut. This is not a problem and has the benefit of preventing the scrap from falling out during the final cuts.
4. Second, set the miter gauge 95 degrees to the left of the blade and crosscut the left-hand notches (when facing the dado) on each leg.
5. Third, set the miter gauge 95 degrees to the right and crosscut the right-hand notches. Break off the waste with your hand, and clean up any remaining wood with a chisel. Now test fit the rails into the notches. The tops of the rails and the tops of the legs should be flush. If either is proud, trim or sand them flush. Next, cut the angle on the sides of the legs with a jigsaw and smooth the cut with a hand plane or sanding block.
6. The arcs at the bottom of the legs come next. Start by drawing a 4" radius circle on a piece of cardboard. Cut it out and use it as a template. Position it according to the dimensions in Fig. 2 and draw the arc. Then cut the arc with a jigsaw. Clean up the rough edges with sandpaper.
7. Rout a bead on the bottom edge of the rails (C). A beading bit creates this classic profile.

8. Draw the arc at the ends of the rails, as shown in Fig. 3, using a cardboard circle template. Cut out each arc with a jigsaw. Clean up the rough edges by sanding as you did before.

9. Cut mortises for the hinges in the back rail. The depth of the mortise should equal the thickness of the hinge when it is closed. Mark the locations of the hinges (Fig. 1) and use the table saw and a dado blade to remove the waste (Fig. 5). Test fit the hinges in the mortises and drill pilot holes for the screws.

### Custom Fit the Bottom

10. The bottom (D) needs to be exactly the same width as the length of the dado in the legs. Place the bottom in the dado, flush-up the edge of the bottom with one side of the dado and mark the exact width on the other side (Fig. 6). Now cut the bottom to final width.

### Assemble the Parts

**NOTE:** If you plan to do a two-tone stain, apply the stain colors before the piece is assembled. See "STAINING AND FINISHING."

11. Begin by building an assembly jig to hold the legs upright during the glue-up. A 2' x 4' sheet of plywood works fine for the base and some scrap 2x2 material is all that's needed for the supports. Rip the edges of the 2x2s on the table saw with the blade set at a 5-degree angle. Then crosscut them so you get four 12"-long pieces. Orient the supports so they hold the legs angled toward each other. Double-faced tape works well to fasten the four angled scraps to the plywood. Position the supports so the bottom inside edges of the legs are 32-1/2" apart. The sides are now held at the right distance from each other, angled at 5 degrees, and with no hands!

12. Dry-fit the rails in the leg notches to make sure they extend 1/2" beyond each end, as shown in Fig 3. Adjust the 2x2 supports if needed.

13. Sand all the parts before gluing. Start with 120-grit sandpaper and work your way up to 220-grit. Also round over any sharp edges on the lid or legs that will be exposed after final assembly.

## FINAL ASSEMBLY

14. To assemble, start by gluing the bottom into the leg dadoes. You'll notice that the dadoes are at a slight angle because the legs are angled in. It's nothing to be concerned about and the bottom will still fit fine. Clamp across the top of the legs to pull the bottom securely into the dadoes. Apply glue to the rails and set them in place. Clamp along the bottom of the rails and at the ends. Clean up any glue squeeze-out with a putty knife after the glue becomes semi-dry. Allow the glue to completely dry before proceeding.

### Peg the Rails to the Legs

15. When the glue is dry, remove the clamps and drill the holes for the pegs (E) that help hold the rails to the legs (Figs. 1 and 3). Drill the holes 1-3/4" deep. Store-bought 3/8" dowel rod will work fine for the pegs, but making your own from the same wood as the bench adds a nice touch.

**16.** To make your own pegs, rip some scraps into 3/8" x 3/8" square rods and round them with a rasp or chisel. Next, cut the rods into 2" lengths. Slightly taper one end of the pegs to make them easier to drive in. Then use a small dowel or stick to smear glue inside the peg hole. Insert the peg and tap it in with a hammer. Trim off the remaining dowel with a handsaw and sand it flush. Be careful you don't damage the rail when trimming the dowels.

**Woodworker's Tip:** *To prevent scratching the rails when flush-trimming the pegs, use a flat piece cut out from a yogurt lid and put a hole in the middle to keep the saw away from the wood. A piece of cardboard or a playing card will also work. Sand off the small amount of dowel that remains.*

### Hinge the Lid

**17.** Screw the hinges into mortises in the back rail. Then mark lines on the underside of the lid for the hinges. Position these lines so when the lid is attached to the bench it is centered from side to side and front to back. Drill holes for the hinge screws. Be careful not to drill through the lid. Now snip the tips off the screws to make them 5/8" long. This keeps them from poking through the top of the lid. Screw the hinges to the lid.

## STAINING AND FINISHING

**Woodworker's Tip:** *Though you may be tempted to cut short your sanding, preparation and application time, don't do it. These tasks are very important steps in obtaining a high-quality finish. Remember, it is the finish, just as much as the fit and smoothness of the parts that will have great bearing on how people judge your craftsmanship. To ensure an excellent result, follow the steps listed in this section and also the instructions the finish manufacturer puts on its products.*

### FINISHING TIPS

- Test the stains and finishes you are planning to use on scraps of wood. On the back of the scrap, mark the stain/finish combination and the type of wood. Allow all samples to dry thoroughly before making your final finish selection. Save your samples for quick reference on future projects.
- All stains and finishes must be allowed to dry thoroughly between coats. Remember that drying times can vary due to humidity and other climatic conditions.
- If you have some leftover stain or finish, wipe the can rim so that stain or finish in the rim won't dry out and prevent the lid from forming a tight seal.
- Brushes used for water-based products, such as Minwax® Water-Based Wood Stains or Minwax® Polycrylic® Protective Finish, should be cleaned with soap and water; oil-based finishes must be cleaned with mineral spirits.

**18.** Sand all pieces with 120-grit paper, then move up to 220-grit to complete the pre-finish smoothing. Use an orbital sander to remove any marks or scratches, then lightly sand by hand using with-the-grain sanding strokes. Wipe the piece carefully with a clean, lint-free cloth lightly dampened with mineral spirits.

### Recommended Finish

Before applying Minwax® Water-Based Wood Stain to a hardwood or softwood, apply Minwax® Water-Based Pre-Stain Wood Conditioner following the directions on the can. After 1 to 5 minutes, wipe off all excess conditioner using a clean, lint-free cloth. Wait 15 to 30 minutes then use fine-grade paper to sand off any "whiskers" raised by the conditioner. Proceed to the staining within 2 hours.

**19.** For two-tone staining, apply the stain prior to assembly. After assembly, you'll only have to dab on and wipe off stain at the ends of the pegs. Apply the Minwax® Water-Based Wood Stain you've chosen using either a nylon/polyester brush or soft cloth. Allow stain to penetrate no longer than 3 minutes. While stain is still wet, wipe off all excess with a clean cloth that's been lightly dampened with stain. Allow the piece to dry for 2 hours before applying a second coat, if desired. Allow the pieces to dry overnight before assembling the bench and applying the protective clear finish.

**Woodworker's Tip:** *Minwax® Water-Based Wood Stain is available in 6 wood tones, a White Wash Pickling Stain, 60 custom-mixed colors, and 8 bold Accents™ colors. This means that you are not limited to just traditional wood colors (pine, oak, walnut, etc.). Instead, you can pick and apply a color to complement the décor of the room in which the bench will be placed. For this reason, make sure you look over all of the Minwax® color charts or check [minwax.com](http://minwax.com) before making your final selection.*

**20.** After allowing the assembled piece to dry overnight, apply Minwax® Polycrylic® Protective Finish following the directions on the can. Stir the can contents thoroughly before starting and periodically repeat the stirring during your work session.

**21.** Working a small area at a time to maintain a wet edge, apply the first coat. Work quickly and make the final strokes in each newly finished section using with-the-grain brushstrokes.

**22.** Allow the finish to dry a minimum of 2 hours. Then sand lightly with 220-grit or finer sandpaper wrapped around a soft backup block. Thoroughly wipe all surfaces with a cloth lightly dampened with water.

**23.** Repeat steps 20 and 21 to apply the second and final coat. For additional protection, you may choose to apply a third coat to the top of the bench.

### Alternate Finish

After the bench is assembled, apply the Minwax® Gel Stain you've chosen to the interior surfaces using a clean, lint-free cloth or natural bristle brush. Allow the Gel Stain to set for about 3 minutes, then wipe off any excess. Repeat for the exterior surfaces. To achieve a deeper color, you may apply a second coat after 8 to 10 hours, repeating the application directions for the first coat. Allow the stain to dry for 24 hours before applying the finish.

**Woodworker's Tip:** *When wiping off stain, make certain that your last wipe with the cloth goes with the grain of the wood. This way, any stain you might miss during wipe-off will be visually minimized by the wood grain.*

**24.** Apply Minwax® Wipe-On Poly following the directions on the can. Shake the can thoroughly. Apply a liberal amount of Wipe-On Poly on a clean, soft, lint-free cloth into the wood. It can be brushed on or wiped on with a cloth. Allow the first coat to dry for at least 4 hours.

**25.** Once completely dry, sand all surfaces very lightly with 220-grit or finer sandpaper or very fine (000) steel wool using with-the-grain strokes. Thoroughly wipe off all surfaces with a soft cloth. Apply a second coat of Minwax® Wipe-On Poly and set the piece aside to dry for at least 4 hours.

**26.** Once completely dry, sand all surfaces lightly with 220-grit or finer sandpaper or very fine (000) steel wool. Thoroughly wipe off the piece with a soft cloth and apply a third and final coat of Wipe-On Poly. Allow the bench to cure for several days before using it.

#### PRODUCT SAFETY

For your safety and the safety of those you work with, always read the safety warnings, which manufacturers print on their labels, and follow them to the letter. Typical safety advice and instructions will contain information such as the following:

**WARNING!** Removal of old paint by sanding, scraping or other means may generate dust or fumes that contain lead. Exposure to lead dust or fumes may cause brain damage or other adverse health effects, especially in children or pregnant women. Controlling exposure to lead or other hazardous substances requires the use of proper protective equipment, such as properly fitted respirator (NIOSH approved) and proper containment and cleanup. For more information, call the National Lead Informations Center at 1-800-424-LEAD (in US) or contact your local health authority.

#### When using oil-based wood finishing products:

**CAUTIONS: CONTAINS ALIPHATIC HYDROCARBONS. Contents are COMBUSTIBLE.** Keep away from heat and open flame. **VAPOR HARMFUL.** Use only with adequate ventilation. To avoid overexposure, open windows and doors or use other means to ensure fresh air entry during application and drying. If you experience eye watering, headaches, or dizziness, increase fresh air, or wear respiratory protection (NIOSH approved) or leave the area. Avoid contact with eyes and skin. Wash hands after using. Keep container closed when not in use. Do not transfer contents to other containers for storage.

**FIRST AID:** In case of eye contact, flush thoroughly with large amounts of water for 15 minutes and get medical attention. For skin contact, wash thoroughly with soap and water. In case of respiratory difficulty, provide fresh air and call physician. If swallowed, call Poison Control Center, hospital emergency room, or physician immediately.

**NOTICE:** Reports have associated repeated and prolonged occupational exposure to solvents with permanent brain and nervous system damage. Intentional misuse by deliberately concentrating and inhaling contents may be harmful or fatal.

**WARNING:** This product contains a chemical known to the State of California to cause cancer and birth defects or other reproductive harm.

**DO NOT TAKE INTERNALLY. KEEP OUT OF REACH OF CHILDREN.**

#### When using water-based wood finishing products:

**CAUTIONS:** Use Only With Adequate Ventilation. To avoid overexposure, open windows and doors or use other means to ensure fresh air entry during application and drying. If you experience eye watering, headaches, or dizziness, increase fresh air, or wear respiratory protection (NIOSH approved), or leave the area. Avoid contact with eyes and skin. Wash hands after using. Keep container closed when not in use. Do not transfer contents to other containers for storage.

**FIRST AID:** In case of eye contact, flush thoroughly with large amounts of water. Get medical attention if irritation persists. If swallowed, get medical attention immediately.

**WARNING:** Contains Alkyl propanols, ethylene glycol, n-methyl pyrrolidone. **VAPOR HARMFUL.** Use only with adequate ventilation. To avoid overexposure, open windows and doors or use other means to ensure fresh air entry during application and drying. If you experience eye watering, headaches, or dizziness, increase fresh air, or wear respiratory protection (NIOSH approved) or leave the area. Avoid contact with eyes and skin. Wash hands after using. Keep container closed when not in use. Do not transfer contents to other containers for storage.

#### DO NOT TAKE INTERNALLY.

**FIRST AID:** In case of eye contact, flush thoroughly with large amounts of water for 15 minutes and get medical attention. For skin contact, wash thoroughly with soap and water. In case of respiratory difficulty, provide fresh air and call physician. If swallowed, call Poison Control Center, hospital emergency room, or physician immediately.

#### DELAYED EFFECTS FROM LONG-TERM OVEREXPOSURE.

Contains solvents which can cause permanent brain and nervous system damage. Intentional misuse by deliberately concentrating and inhaling contents may be harmful or fatal.

**WARNING:** This product contains a chemical known to the State of California to cause cancer and birth defects or other reproductive harm.

**KEEP OUT OF REACH OF CHILDREN.**

#### SAFE DISPOSAL OF RAGS AND WASTE.

**DANGER:** Rags, steel wool, other waste soaked with this product, and sanding residue may spontaneously catch fire if improperly discarded. Immediately place rags, steel wool, other waste soaked with this product, and sanding residue in a sealed, water-filled, metal container. Dispose of in accordance with local fire regulations.

This project was adapted with permission from *American Woodworker* magazine, Home Services Publications, Inc., an affiliate of Reader's Digest Association, Inc., Suite 700, 2915 Commers Drive, Eagan, MN 55121. ©Copyright 2004. All rights reserved. For subscriptions call toll-free: 1-800-666-3111.

**FIG 1. BENCH DETAILS**

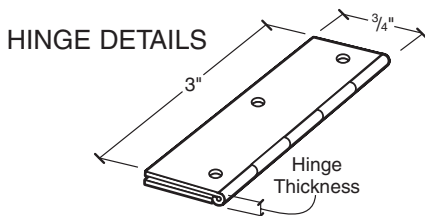
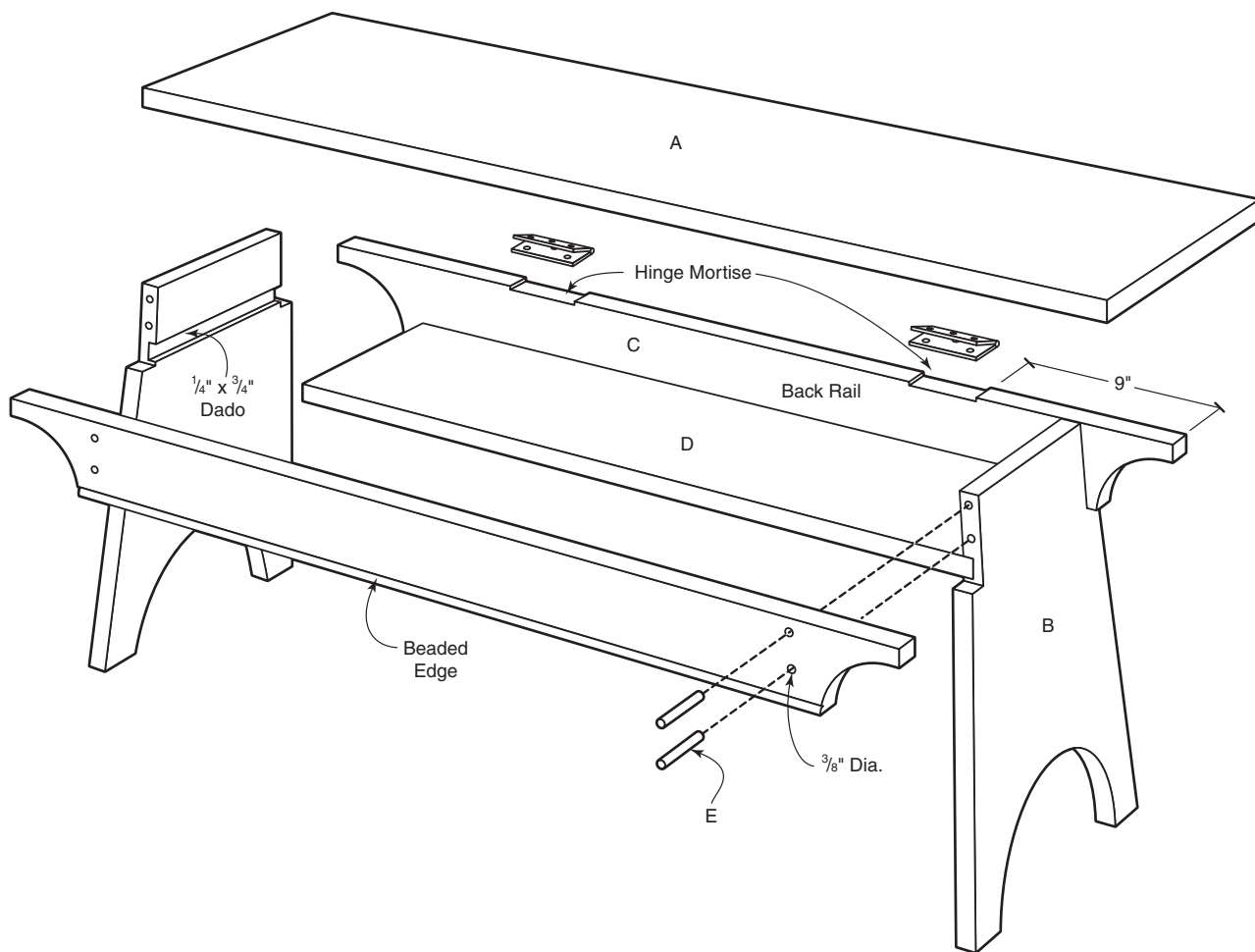

**FIG 2. CUTTING DIMENSIONS FOR LEGS**

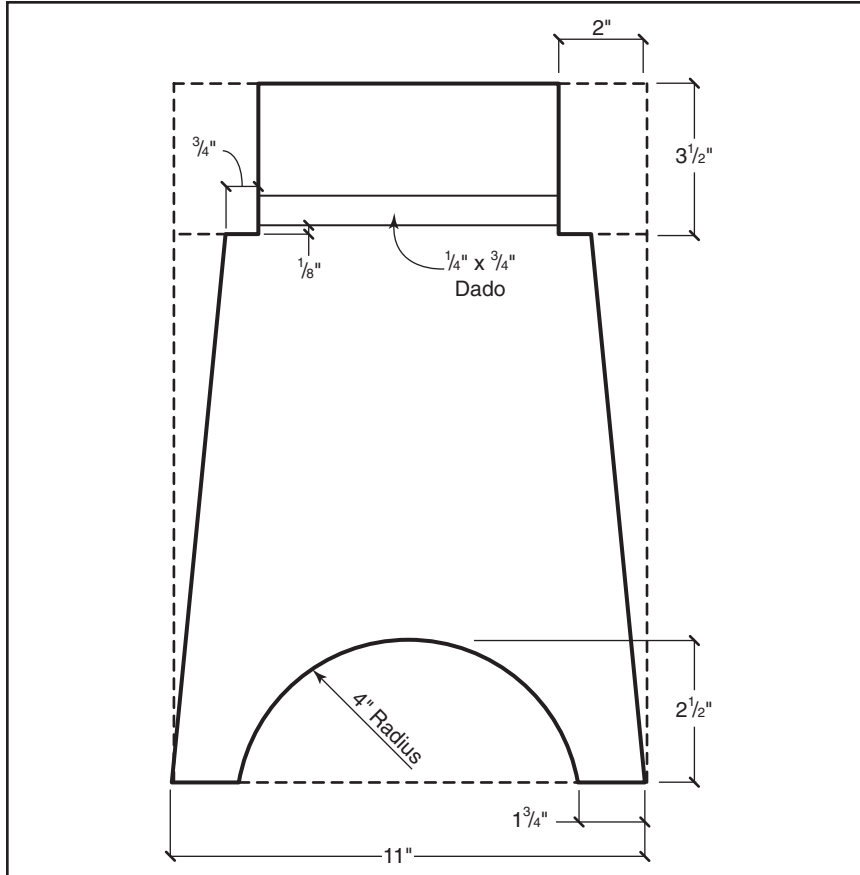

**FIG 3. RAIL DETAIL**

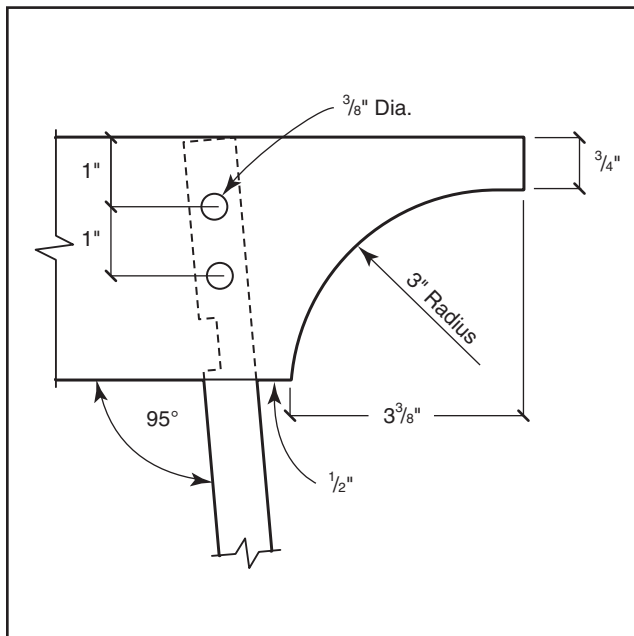

**FIG 4. CUTTING THE LEGS**

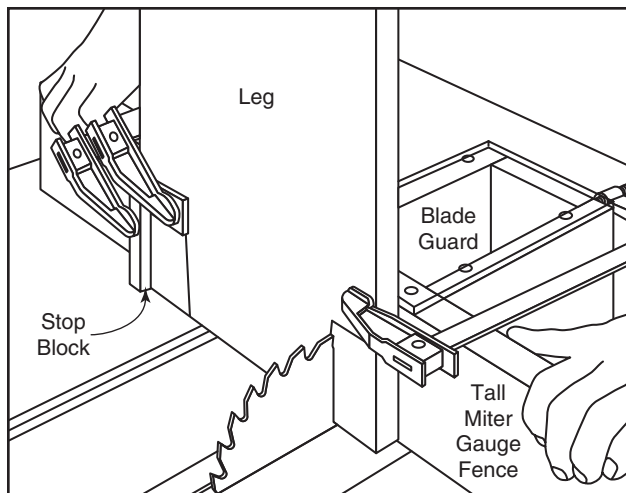

**FIG 5. CUTTING THE BACK RAIL**

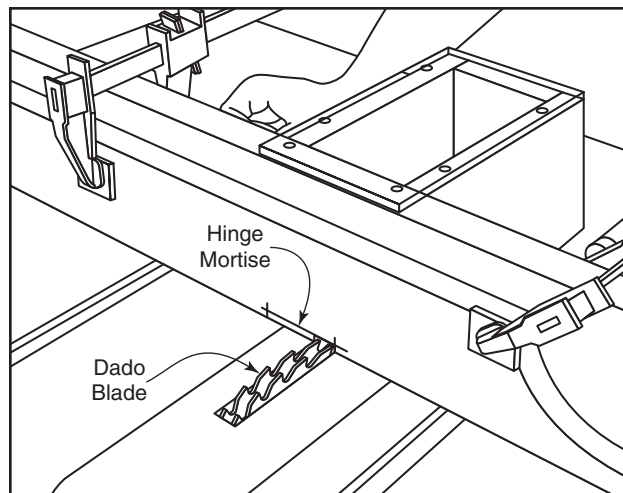

**FIG 6. CUSTOM FIT THE BOTTOM**

